

NAME **Daniel Hiesch**
 RACE **RCK Kleinserie**
 TRACK **EMC Marktoberdorf**
 COUNTRY **Germany** CLASS **21.5T**

DATE **03.05.26** TEMP. °C AIR / TRACK **21 /**
 TRACK SURFACE ASPHALT CARPET
 TRACK LAYOUT TECHNICAL MIXED FAST
 TRACTION LOW MEDIUM HIGH

FRONT

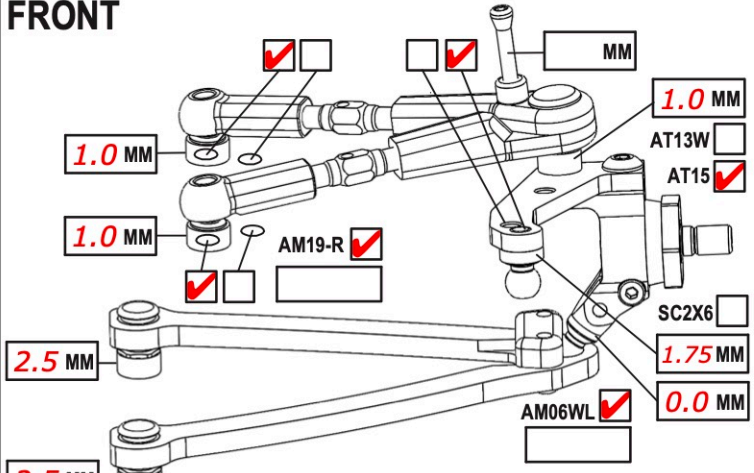

CAMBER ANGLE / ° **1.5**
 CASTER ANGLE / ° **4.5**
 TOE ANGLE / ° **1.0**
 RIDE HEIGHT / MM **5.0**
 DOWNSTOP / MM **5.6**
 UPSTOP / MM **/**
 ANTI-ROLL BAR Ø / MM **1.0**
 ARB STIFFENER 1/4 1/2 3/4 1
 LOWER ARM EXTENSION / MM **0**
 STEER. ARM AM14LS
 2ND SPRING SPR-P2 P1
 WHEEL SPACER / MM **0.0**
 DRIVE SPOOL DIFF
 DRIVE POSITION DOWN UP +1
 DIFF OIL DIFF SHIMS

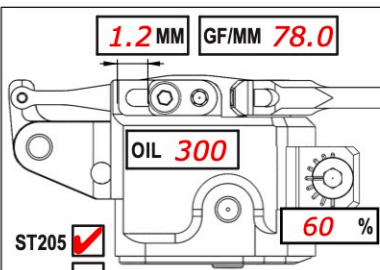

SHOCKS SETUP
 DAMPER D4
 ROTOR 2 HOLES
 SPRING STD S
 SRS/RHS ARR. I II
 PSS SETUP 30% 25% 15%
 DAMPING LINEAR P1 P2
 DAMPER SPACER / MM
 C45 YES NO

REAR

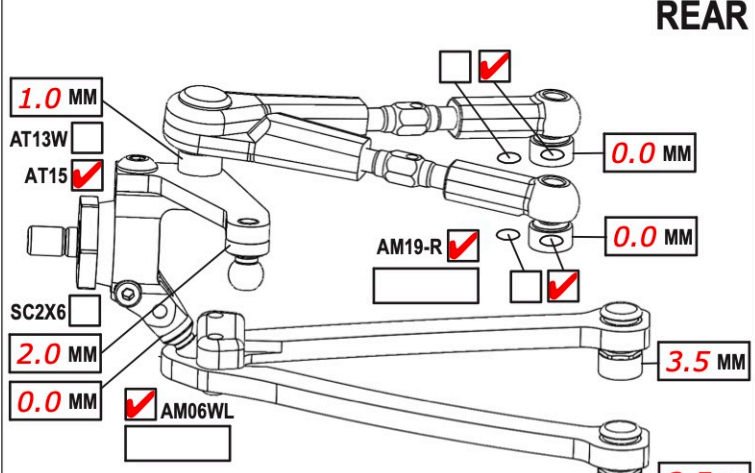

CAMBER ANGLE / ° **1.5**
 CASTER ANGLE / ° **4**
 TOE ANGLE / ° **1.5**
 RIDE HEIGHT / MM **5.2**
 DOWNSTOP / MM **4.2**
 UPSTOP / MM **/**
 ANTI-ROLL BAR Ø / MM **1.1**
 ARB STIFFENER 1/4 1/2 3/4 1
 LOWER ARM EXTENSION / MM **0**
 STEER. ARM AM23-1
 2ND SPRING SPR-P2 P1
 WHEEL SPACER / MM **0.0**
 DRIVE SPOOL DIFF
 DRIVE POSITION DOWN UP +1
 DIFF OIL **7000** DIFF SHIMS **sh5x7x0.4**

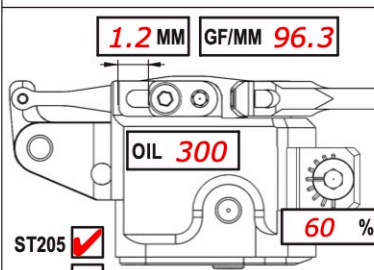

SHOCKS SETUP
 DAMPER D4
 ROTOR 2 HOLES
 SPRING STD S
 SRS/RHS ARR. I II
 PSS SETUP 30% 25% 15%
 DAMPING LINEAR P1 P2
 DAMPER SPACER / MM
 C45 YES NO

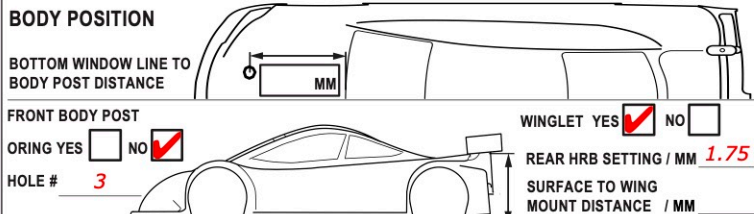
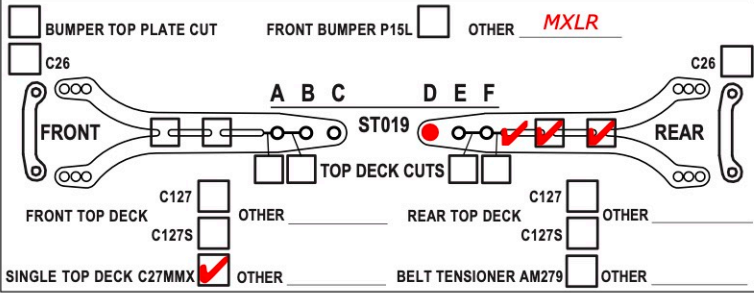
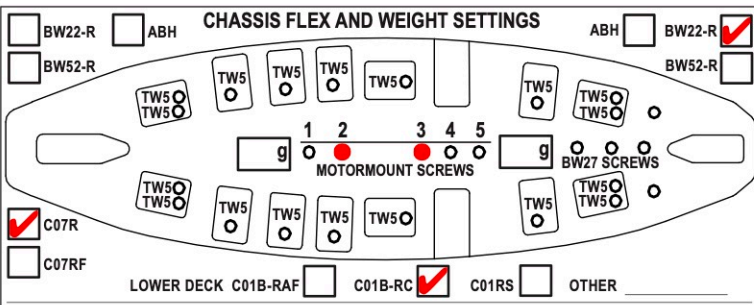

TIRES **Rck 36**
 INSERTS
 SIDE WALLS GLUE Ø / MM F R
 ADDITIVE **phub hybrid** TIME MIN. F **2x25** R **75°**
 TOTAL WEIGHT **1322** WEIGHT DISTRIBUTION % F **49.5** R **50.5**
 NOTES:

MOTOR LATERAL SHIFT / MM
 MOTOR **Rck 17.5**
 SPUR **100** PINION **47** RATIO **4.04**
 BODY **Wolverine 0.4**
 WING **Wolverine**
 ESC **Hobbywing G3X**
 BEST LAPTIME
 SERVO **Savox**
 SERVOHORN / HEIGHT **17mm**
 ACKERMANN POSITION **forward**
 STEER TRAVEL IN **25** OUT
 BATTERY **Team Eam 6400**
 RECEIVER **Sanwa**
 RADIO **Sanwa**
 QUALIF./FINAL POSITION **/**

COMMENTS:
ultra gripy flat curbs