

NAME **Thiersch Johann**  
 RACE **RCK**  
 TRACK **Zwickau**  
 COUNTRY **DE** CLASS **17.5T**

DATE **17.05.2026** TEMP. °C AIR / TRACK **20 / 20**  
 TRACK SURFACE ASPHALT  CARPET   
 TRACK LAYOUT TECHNICAL  MIXED  FAST   
 TRACTION LOW  MEDIUM  HIGH

### FRONT

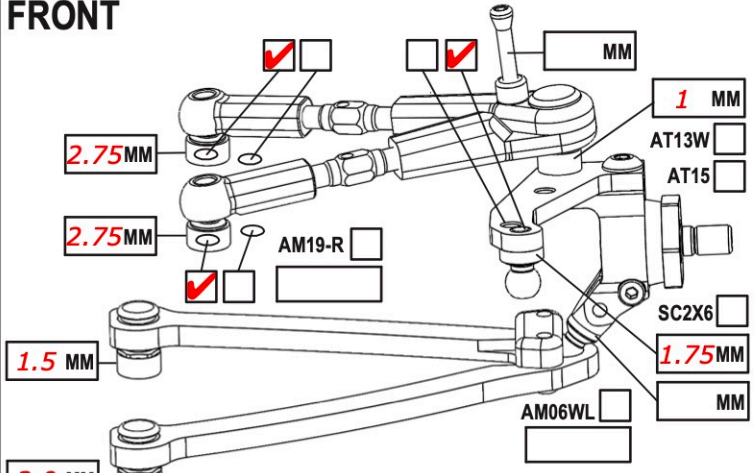

CAMBER ANGLE / ° **2.5**  
 CASTER ANGLE / ° **4**  
 TOE ANGLE / ° **1**  
 RIDE HEIGHT / MM **5.4**  
 DOWNSTOP / MM **5.6**  
 UPSTOP / MM  
 ANTI-ROLL BAR Ø / MM **1.2**  
 ARB STIFFENER 1/4  1/2  3/4  1   
 LOWER ARM EXTENSION / MM **0**  
 STEER. ARM AM14LS   
 2ND SPRING SPR-P2  P1   
 WHEEL SPACER / MM  
 DRIVE SPOOL  DIFF   
 DRIVE POSITION DOWN  UP  +1   
 DIFF OIL DIFF SHIMS

**SHOCKS SETUP**

0.4MM GF/MM **57.0**  
 OIL **300**  
 60 %  
 ST205  ST05-R   
 DAMPER D4   
 ROTOR 2 HOLES   
 SPRING STD  S   
 SRS/RHS ARR. I  II   
 PSS SETUP 30%  25%  15%   
 DAMPING LINEAR  P1  P2   
 DAMPER SPACER / MM **ST 237**  
 C45 YES  NO

### REAR

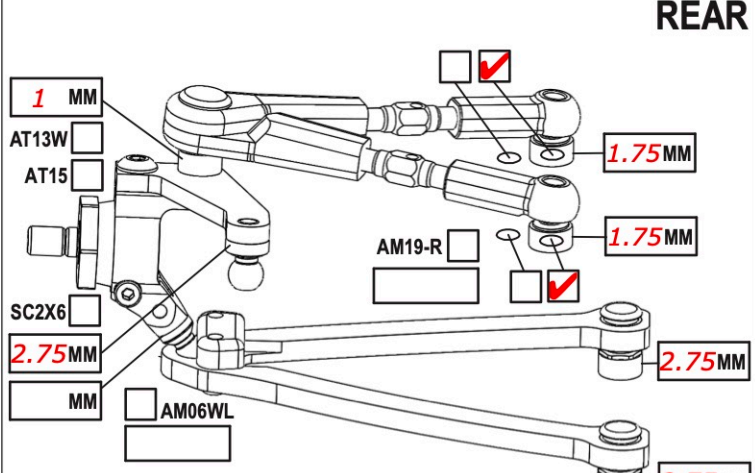

CAMBER ANGLE / ° **2.5**  
 CASTER ANGLE / ° **-3**  
 TOE ANGLE / ° **2.5**  
 RIDE HEIGHT / MM **5.6**  
 DOWNSTOP / MM **4.6**  
 UPSTOP / MM  
 ANTI-ROLL BAR Ø / MM **1.1**  
 ARB STIFFENER 1/4  1/2  3/4  1   
 LOWER ARM EXTENSION / MM **0**  
 STEER. ARM AM23-1   
 2ND SPRING SPR-P2  P1   
 WHEEL SPACER / MM  
 DRIVE DIFF  **Diff**  
 DRIVE POSITION DOWN  UP  +1   
 DIFF OIL **8k** DIFF SHIMS **SS 0.4**

**SHOCKS SETUP**

2.2MM GF/MM **10077010222**  
 OIL **300**  
 60 %  
 ST205  ST05-R   
 DAMPER D4   
 ROTOR 2 HOLES   
 SPRING STD  S   
 SRS/RHS ARR. I  II   
 PSS SETUP 30%  25%  15%   
 DAMPING LINEAR  P1  P2   
 DAMPER SPACER / MM **ST 237**  
 C45 YES  NO

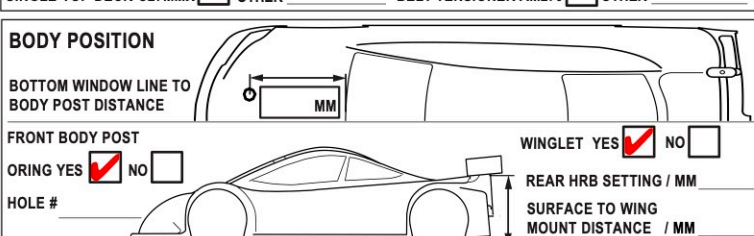
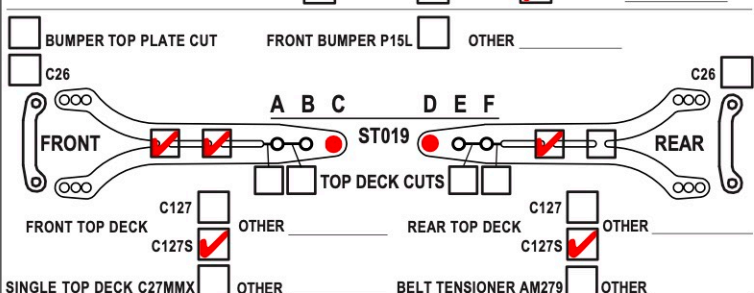
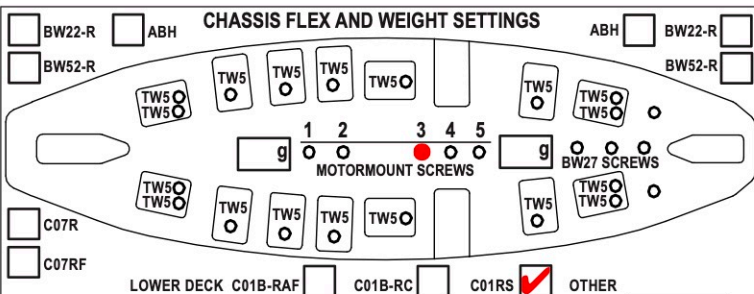

TIRES **RCK**  
 INSERTS  
 SIDE WALLS GLUE Ø / MM F R  
 ADDITIVE **MX Side Bite** TIME MIN. F **30** R **30**  
 TOTAL WEIGHT **1320** WEIGHT DISTRIBUTION % F **49** R **51**

NOTES:

MOTOR LATERAL SHIFT / MM  
 MOTOR **RCK 17.5**  
 SPUR PINION **1** RATIO **0**  
 BODY **Zoo Wolverine 0.4**  
 WING **0.4**  
 ESC **HW XR10**  
 ESC SETTING  
 BEST LAPTIME **17,9** QUALIF./FINAL POSITION **4 / 3**

SERVO **Power HD S15**  
 SERVOHORN / HEIGHT **18**  
 ACKERMANN POSITION **max. forw.**  
 STEER TRAVEL IN **26** OUT  
 BATTERY **EAM 6000**  
 RECEIVER **Sanwa**  
 RADIO **Sanwa**

COMMENTS: