

NAME **Roman Borschel**
 RACE **ETS**
 TRACK **Sporthotel Grafenwald Daun**
 COUNTRY **Germany** CLASS **17.5T**

DATE **29.01.-01.02.2026** TEMP. °C AIR / TRACK **23 /**
 TRACK SURFACE ASPHALT CARPET
 TRACK LAYOUT TECHNICAL MIXED FAST
 TRACTION LOW MEDIUM HIGH

FRONT

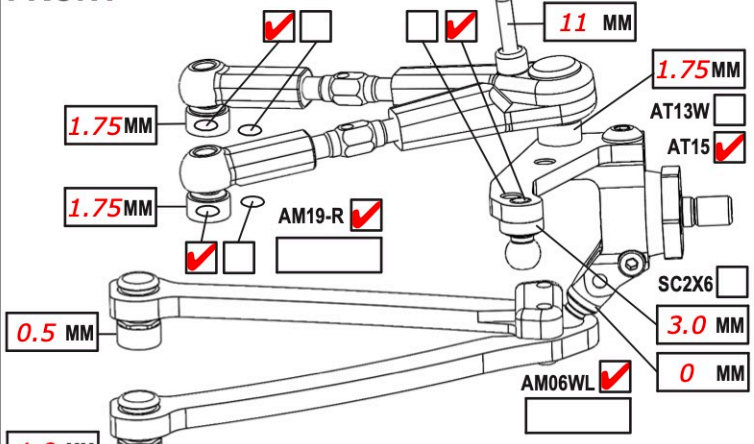

CAMBER ANGLE / ° **1.0**
 CASTER ANGLE / ° **4**
 TOE ANGLE / ° **1.0**
 RIDE HEIGHT / MM **5.0**
 DOWNSTOP / MM **5.8**
 UPSTOP / MM **33.4**
 ANTI-ROLL BAR Ø / MM **1.1**
 ARB STIFFENER 1/4 1/2 3/4 1
 LOWER ARM EXTENSION / MM **0**
 STEER. ARM AM14LS **AM14H**
 2ND SPRING SPR-P2 P1
 WHEEL SPACER / MM **-**
 DRIVE SPOOL DIFF
 DRIVE POSITION DOWN UP +1
 DIFF OIL DIFF SHIMS **SH5X7X0.4**

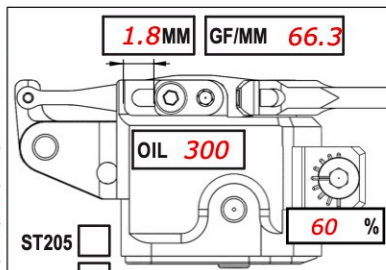

SHOCKS SETUP
 ST205 ST05-R
 DAMPER **D4**
 ROTOR 2 HOLES
 SPRING **STD** **S**
 SRS/RHS ARR. **I** **II**
 PSS SETUP 30% 25% 15%
 DAMPING LINEAR P1 P2
 DAMPER SPACER / MM **ST237**
 C45 **YES** **NO**

REAR

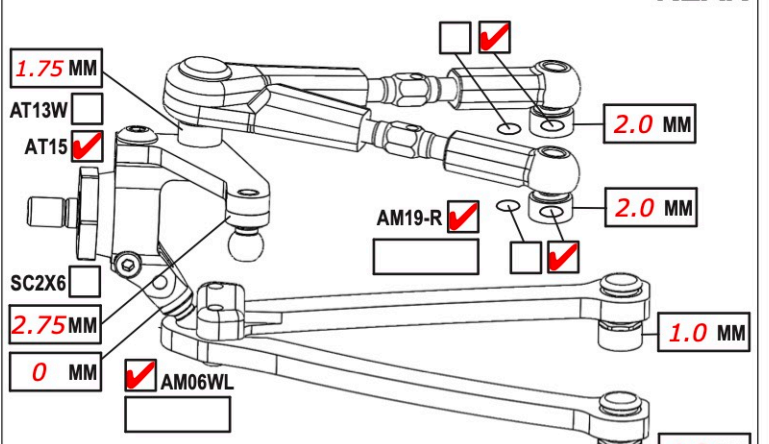

CAMBER ANGLE / ° **1.5**
 CASTER ANGLE / ° **-2**
 TOE ANGLE / ° **3.0**
 RIDE HEIGHT / MM **5.2**
 DOWNSTOP / MM **4.8**
 UPSTOP / MM **33.4**
 ANTI-ROLL BAR Ø / MM **1.1**
 ARB STIFFENER 1/4 1/2 3/4 1
 LOWER ARM EXTENSION / MM **0**
 STEER. ARM AM23-1
 2ND SPRING SPR-P2 P1
 WHEEL SPACER / MM **-**
 DRIVE SPOOL DIFF
 DRIVE POSITION DOWN UP +1
 DIFF OIL **7k** DIFF SHIMS **GD2B-R**

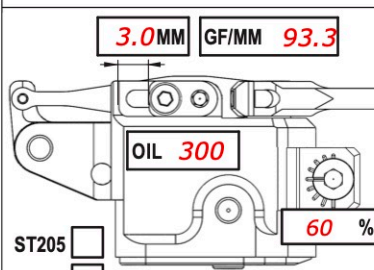

SHOCKS SETUP
 ST205 ST05-R
 DAMPER **D4**
 ROTOR 2 HOLES
 SPRING **STD** **S**
 SRS/RHS ARR. **I** **II**
 PSS SETUP 30% 25% 15%
 DAMPING LINEAR P1 P2
 DAMPER SPACER / MM **ST237**
 C45 **YES** **NO**

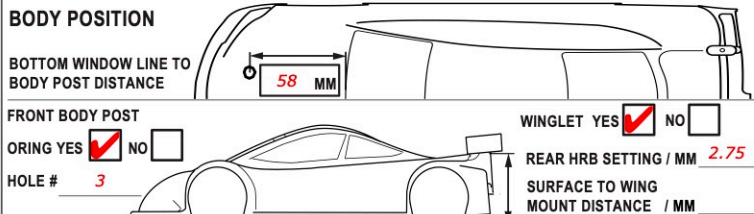
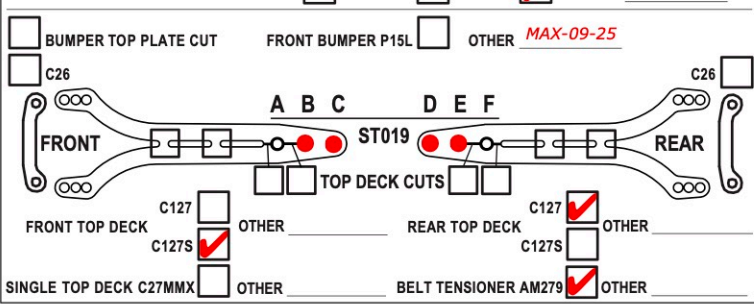
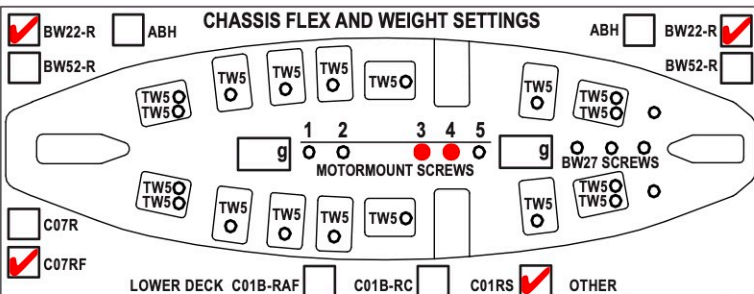

TIRES **Matrix MX-EPCZ-028**
 INSERTS **STD**
 SIDE WALLS GLUE Ø / MM F **59** R
 ADDITIVE **MR33 V5** TIME MIN. F **15** R **15**
 TOTAL WEIGHT **1305** WEIGHT DISTRIBUTION % F **50** R **50**

NOTES:
 MOTOR LATERAL SHIFT / MM **1** SERVO **Power HD S15**
 MOTOR **HW-30401760 Handout** SERVOHORN / HEIGHT **19mm**
 SPUR PINION **1** RATIO **0.00** ACKERMANN POSITION **Back**
 BODY **Zooracing Wolverine 0.4** STEER TRAVEL IN **26** OUT
 WING **Twister 0.5** BATTERY **Team Eam 5200**
 ESC **HW-30112103** RECEIVER **Sanwa RX-482**
 ESC SETTING RADIO **Sanwa M17**
 BEST LAPTIME **14,8** QUALIF./FINAL POSITION **11 / 11**

COMMENTS: