

NAME **Delalandre Jeremy**  
 RACE **National 2**  
 TRACK **LCML Loos**  
 COUNTRY **France** CLASS **13.5T**

DATE **25-26/04/26** TEMP. °C AIR / TRACK **22 /**  
 TRACK SURFACE ASPHALT  CARPET   
 TRACK LAYOUT TECHNICAL  MIXED  FAST   
 TRACTION LOW  MEDIUM  HIGH

### FRONT

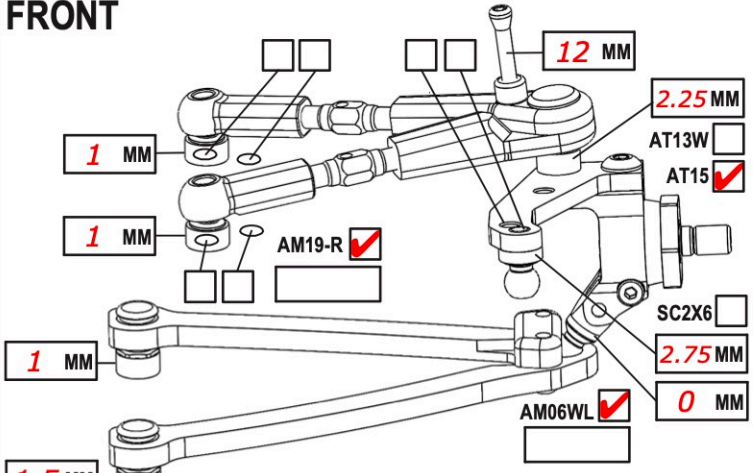

CAMBER ANGLE / ° **2**  
 CASTER ANGLE / ° **4.5**  
 TOE ANGLE / ° **1.2**  
 RIDE HEIGHT / MM **4.8**  
 DOWNSTOP / MM **23.6**  
 UPSTOP / MM **32**  
 ANTI-ROLL BAR Ø / MM **1.1**  
 ARB STIFFENER 1/4  1/2  3/4  1   
 LOWER ARM EXTENSION / MM **0**  
 STEER. ARM AM14LS   
 2ND SPRING SPR-P2  P1   
 WHEEL SPACER / MM  
 DRIVE SPOOL  DIFF   
 DRIVE POSITION DOWN  UP  +1  
 DIFF OIL DIFF SHIMS

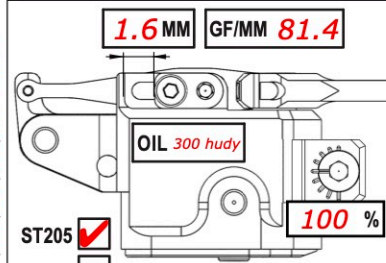

SHOCKS SETUP  
 DAMPER D4   
 ROTOR 2 HOLES   
 SPRING STD  S   
 SRS/RHS ARR. I  II   
 PSS SETUP 30%  25%  15%   
 DAMPING LINEAR  P1  P2   
 DAMPER SPACER / MM **ST237**  
 C45 YES  NO

### REAR

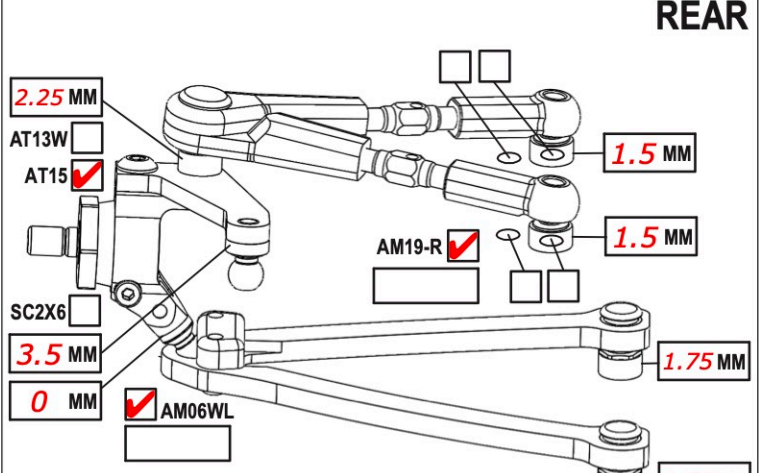

CAMBER ANGLE / ° **2**  
 CASTER ANGLE / ° **3**  
 TOE ANGLE / ° **2.75**  
 RIDE HEIGHT / MM **5**  
 DOWNSTOP / MM **22.6**  
 UPSTOP / MM **32**  
 ANTI-ROLL BAR Ø / MM **1.1**  
 ARB STIFFENER 1/4  1/2  3/4  1   
 LOWER ARM EXTENSION / MM **0**  
 STEER. ARM AM23-1   
 2ND SPRING SPR-P2  P1   
 WHEEL SPACER / MM  
 DRIVE DIFF   
 DRIVE POSITION DOWN  UP  +1  
 DIFF OIL **8k** DIFF SHIMS **SH5X7X0.4**

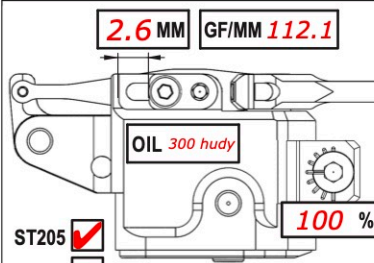

SHOCKS SETUP  
 DAMPER D4   
 ROTOR 2 HOLES   
 SPRING STD  S   
 SRS/RHS ARR. I  II   
 PSS SETUP 30%  25%  15%   
 DAMPING LINEAR  P1  P2   
 DAMPER SPACER / MM **ST237**  
 C45 YES  NO

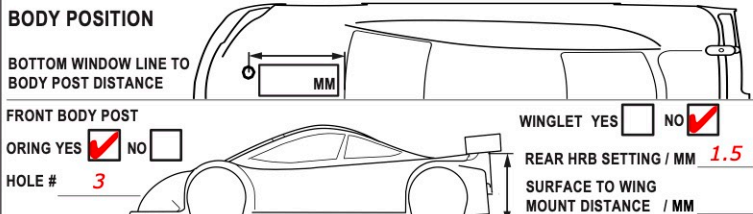
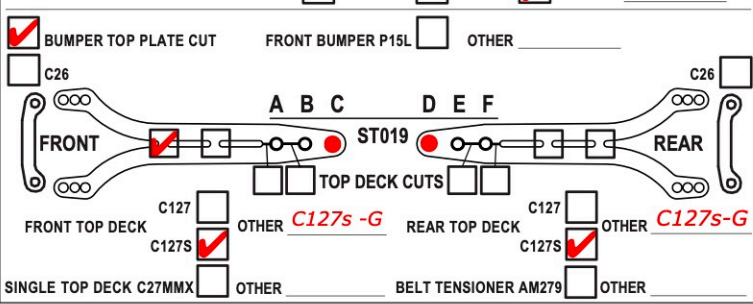
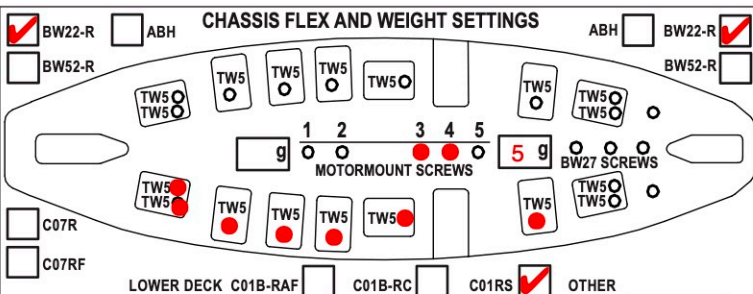

TIRES **Sweep D40**  
 INSERTS  
 SIDE WALLS GLUE Ø / MM F R  
 ADDITIVE **Phub pink** TIME MIN. F **15** R **15**  
 TOTAL WEIGHT **1303** WEIGHT DISTRIBUTION % F **50** R **50**  
 NOTES: **2nd tape with paper**

MOTOR LATERAL SHIFT / MM **0** SERVO **Power HD S15**  
 MOTOR **Ruddog 13.5** SERVOHORN / HEIGHT **17 mr33 alu**  
 SPUR **98** PINION **43** RATIO **4.33** ACKERMANN POSITION **Back**  
 BODY **Zoo wolwerine** STEER TRAVEL IN **25** OUT **18**  
 WING **Xtreme** BATTERY **Ruddog RR2 7100**  
 ESC **Ruddog RXS** RECEIVER **Ruddog RR492**  
 ESC SETTING RADIO **Sanwa M17**  
 BEST LAPTIME **12.4** QUALIF./FINAL POSITION **4 / 3**

COMMENTS:  
 Diff checker:195  
 AM14H/AM23-1/P03XR/alu screw on top/AT144/plastic bumper plat cut  
 MXLR tungsten