

NAME **Ji-heon Yoo**
 RACE **GF raceway opening race**
 TRACK **GF raceway**
 COUNTRY **south korea** CLASS **Mod**

DATE **26.06.21** TEMP. °C AIR / TRACK **30 /**
 TRACK SURFACE ASPHALT CARPET
 TRACK LAYOUT TECHNICAL MIXED FAST
 TRACTION LOW MEDIUM HIGH

FRONT

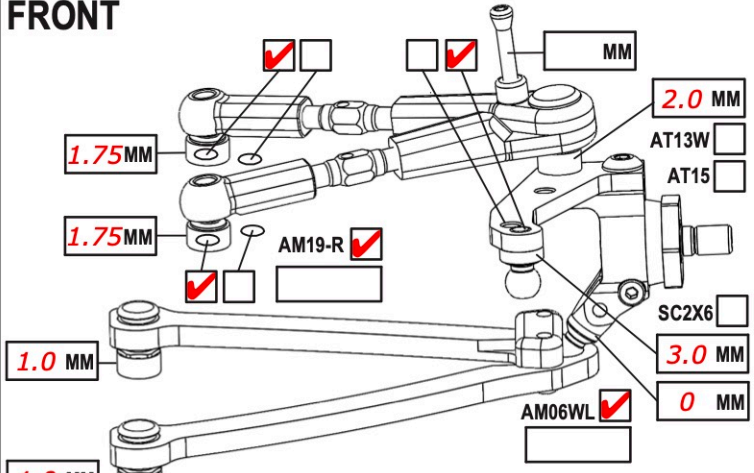

CAMBER ANGLE / ° **2.0**
 CASTER ANGLE / ° **4.0**
 TOE ANGLE / ° **1.2**
 RIDE HEIGHT / MM **4.7**
 DOWNSTOP / MM **5.8**
 UPSTOP / MM **0**
 ANTI-ROLL BAR Ø / MM **1.1**
 ARB STIFFENER 1/4 1/2 3/4 1
 LOWER ARM EXTENSION / MM **0**
 STEER. ARM AM14LS
 2ND SPRING SPR-P2 P1
 WHEEL SPACER / MM **0**
 DRIVE SPOOL DIFF
 DRIVE POSITION DOWN UP +1
 DIFF OIL DIFF SHIMS

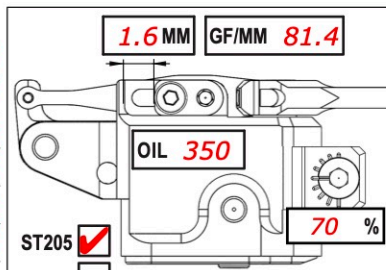

SHOCKS SETUP
 ST205 ST05-R
 DAMPER D4
 ROTOR 2 HOLES
 SPRING STD S
 SRS/RHS ARR. I II
 PSS SETUP 30% 25% 15%
 DAMPING LINEAR P1 P2
 DAMPER SPACER / MM **+ST237**
 C45 YES NO

REAR

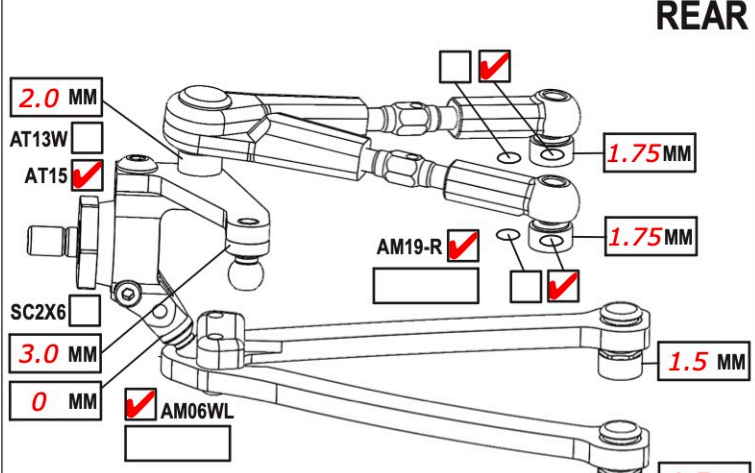

CAMBER ANGLE / ° **2.0**
 CASTER ANGLE / ° **-2.0**
 TOE ANGLE / ° **2.75**
 RIDE HEIGHT / MM **5.1**
 DOWNSTOP / MM **4.6**
 UPSTOP / MM **0**
 ANTI-ROLL BAR Ø / MM **1.1**
 ARB STIFFENER 1/4 1/2 3/4 1
 LOWER ARM EXTENSION / MM **0**
 STEER. ARM AM23-1
 2ND SPRING SPR-P2 P1
 WHEEL SPACER / MM **0**
 DRIVE DIFF
 DRIVE POSITION DOWN UP +1
 DIFF OIL **MR33 7k** DIFF SHIMS **SH5x15.5x0.3**

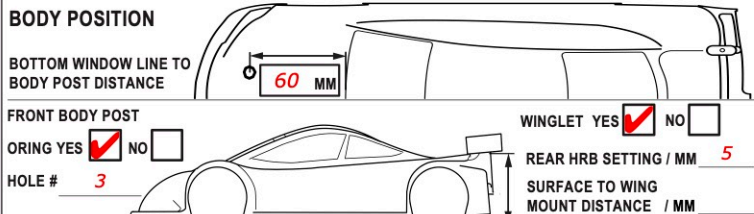
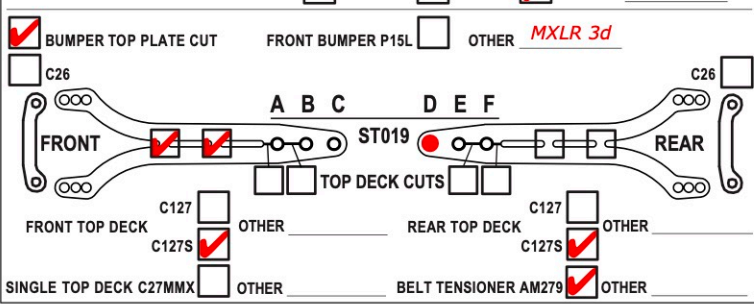
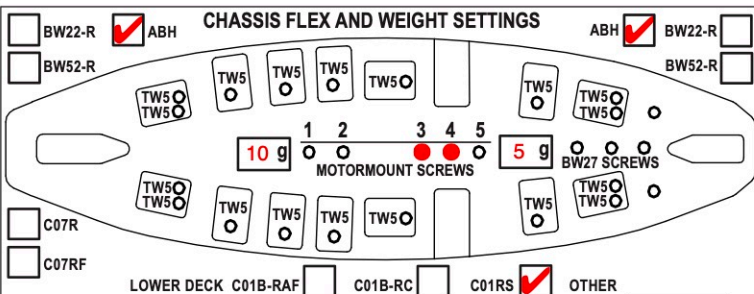
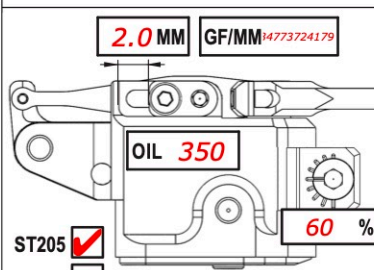

TIRES **SWEEP D36**
 INSERTS **PINK**
 SIDE WALLS GLUE Ø / MM F **0** R **0**
 ADDITIVE **MG V3 Yellow** TIME MIN. F **15** R **15**
 TOTAL WEIGHT **1302** WEIGHT DISTRIBUTION % F **51** R **49**
 NOTES: **70deg warming**

MOTOR LATERAL SHIFT / MM **12.3** SERVO **PowerHD GTS-2**
 MOTOR **Hobbywing 5T (35°)** SERVOHORN / HEIGHT **17mm MXLR**
 SPUR **111** PINION **29** RATIO **793103447** ACKERMANN POSITION **backward**
 BODY **Xtreme Speciale UL** STEER TRAVEL IN **25** OUT **16.5**
 WING **Xtreme Speciale UL** BATTERY **LRP 7200**
 ESC **HW XR10 Pro G3** RECEIVER **Sanwa 492**
 ESC SETTING RADIO **Sanwa M17s**
 BEST LAPTIME **12.1** QUALIF./FINAL POSITION **TQ / 1st**

COMMENTS:
BW10, BW7, BW8, AT21-Ti, BS1-Ti, ST03-Ti SB3X5AL Screws on top of the car