

NAME **Michele Manzo**
 RACE **Swiss Nationals Rd2**
 TRACK **Dintikon**
 COUNTRY **CH** CLASS **17.5T**

DATE **16-17.05.26** TEMP. °C AIR / TRACK **25 /**
 TRACK SURFACE ASPHALT CARPET
 TRACK LAYOUT TECHNICAL MIXED FAST
 TRACTION LOW MEDIUM HIGH

FRONT

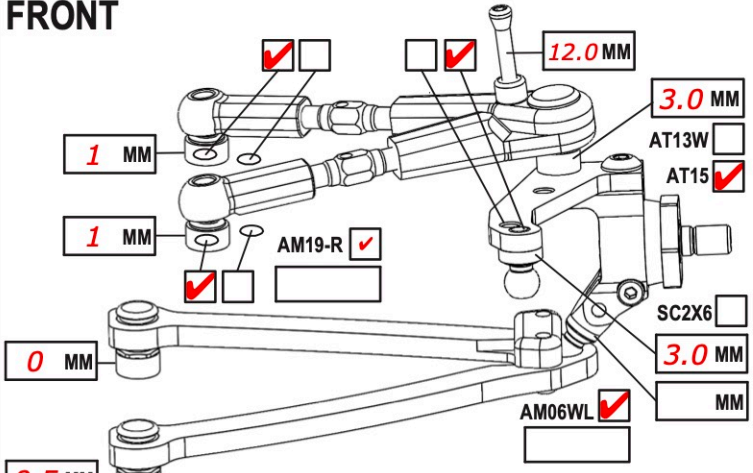

CAMBER ANGLE / ° **1.5**
 CASTER ANGLE / ° **4.5**
 TOE ANGLE / ° **1.5**
 RIDE HEIGHT / MM **4.8**
 DOWNSTOP / MM **6.0**
 UPSTOP / MM **33.4**
 ANTI-ROLL BAR Ø / MM **1.1**
 ARB STIFFENER 1/4 1/2 3/4 1
 LOWER ARM EXTENSION / MM **0**
 STEER. ARM AM14LS
 2ND SPRING SPR-P2 P1
 WHEEL SPACER / MM **0**
 DRIVE SPOOL DIFF
 DRIVE POSITION DOWN UP +1
 DIFF OIL DIFF SHIMS

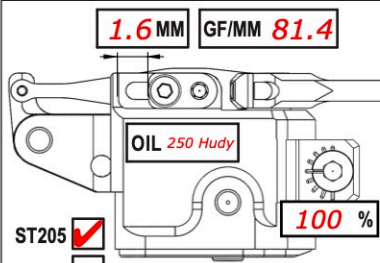

SHOCKS SETUP
 ST205 ST05-R
 DAMPER D4
 ROTOR 2 HOLES
 SPRING STD S
 SRS/RHS ARR. I II
 PSS SETUP 30% 25% 15%
 DAMPING LINEAR P1 P2
 DAMPER SPACER / MM **ST237**
 C45 YES NO

REAR

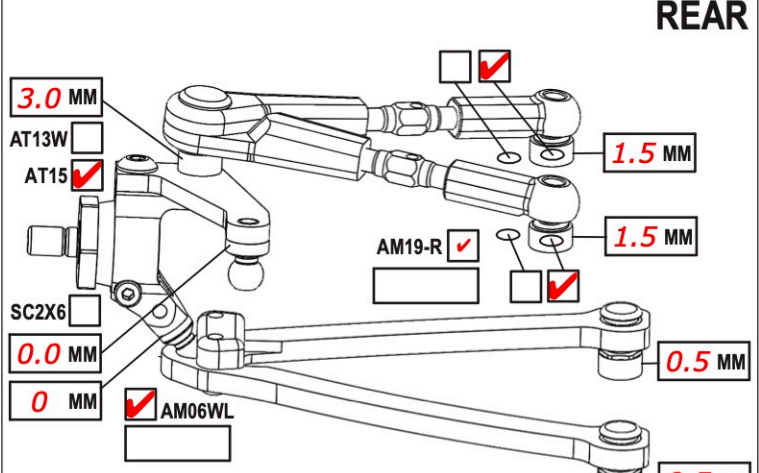

CAMBER ANGLE / ° **1.5**
 CASTER ANGLE / ° **-3.0**
 TOE ANGLE / ° **2.8**
 RIDE HEIGHT / MM **5.0**
 DOWNSTOP / MM **4.6**
 UPSTOP / MM **22.8**
 ANTI-ROLL BAR Ø / MM **1.1**
 ARB STIFFENER 1/4 1/2 3/4 1
 LOWER ARM EXTENSION / MM **-1**
 STEER. ARM AM23-1
 2ND SPRING SPR-P2 P1
 WHEEL SPACER / MM **0**
 DRIVE SPOOL DIFF
 DRIVE POSITION DOWN UP +1
 DIFF OIL **8K** DIFF SHIMS **Small**

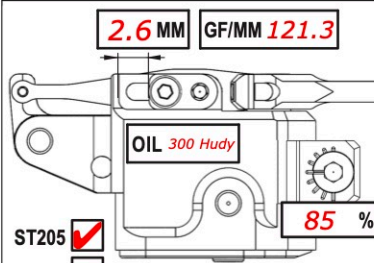

SHOCKS SETUP
 ST205 ST05-R
 DAMPER D4
 ROTOR 2 HOLES
 SPRING STD S
 SRS/RHS ARR. I II
 PSS SETUP 30% 25% 15%
 DAMPING LINEAR P1 P2
 DAMPER SPACER / MM **ST237**
 C45 YES NO

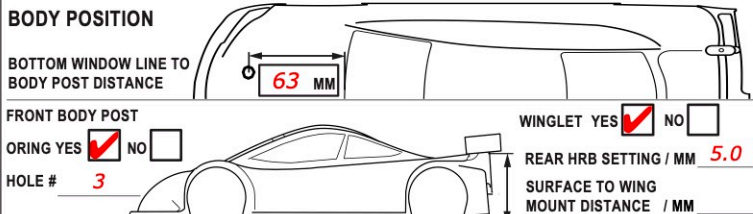
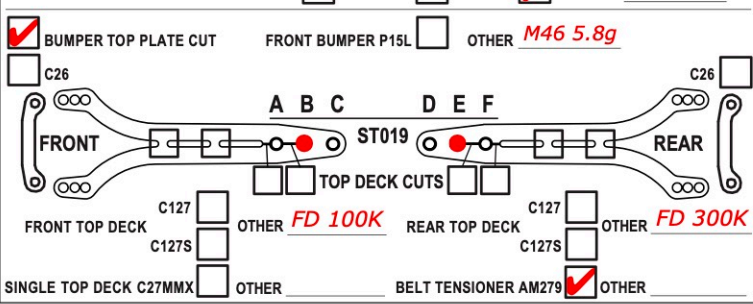
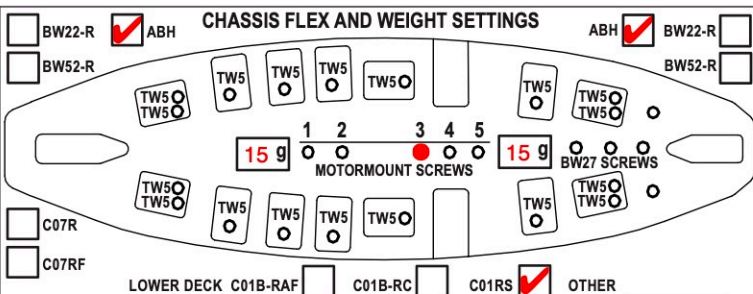

TIRES **Sweep D36**
 INSERTS
 SIDE WALLS GLUE Ø / MM F - R -
 ADDITIVE **Sweep X5** TIME MIN. F **20** R **20**
 TOTAL WEIGHT **1303** WEIGHT DISTRIBUTION % F **49** R **51**
 NOTES:

MOTOR LATERAL SHIFT / MM **0** SERVO **MKS HBL575SL**
 MOTOR **HW G4 17.5t** SERVOHORN / HEIGHT **17mm**
 SPUR **100** PINION **42** RATIO **4.52** ACKERMANN POSITION **rearward**
 BODY **Jackal 0.4** STEER TRAVEL IN **25** OUT **16**
 WING **std.** BATTERY **Team EAM ULCG 4200**
 ESC **HW XR10 Pro G3** RECEIVER **RX 492**
 ESC SETTING RADIO **Sanwa M17**
 BEST LAP TIME **14.9** QUALIF./FINAL POSITION **1 / 1**

COMMENTS:
BS1-Ti - ST03Ti
Inner ARS link 1mm shimed
Modded/Flex P01X/P02