

NAME **Lukas Ellerbrock**
 RACE **TOS Apeldoorn - Steel Car**
 TRACK **Apeldoorn**
 COUNTRY **Netherlands** CLASS **17.5T**

DATE **26.04.2026** TEMP. °C AIR / TRACK **16 /**
 TRACK SURFACE ASPHALT CARPET
 TRACK LAYOUT TECHNICAL MIXED FAST
 TRACTION LOW MEDIUM HIGH

FRONT

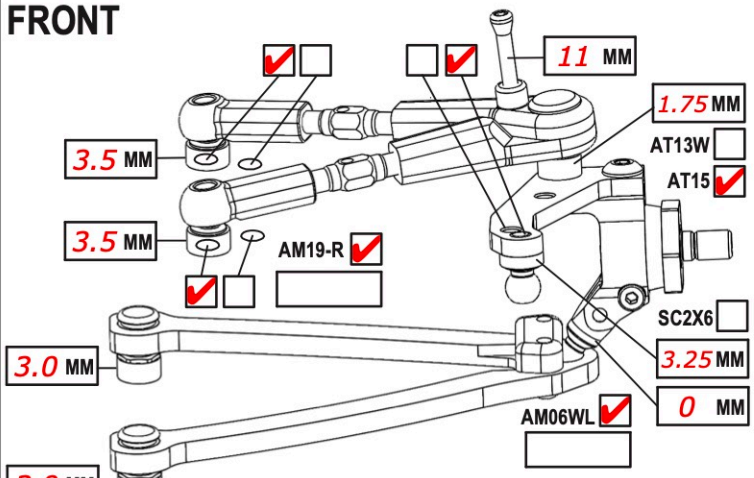

CAMBER ANGLE / ° **2.0**
 CASTER ANGLE / ° **4.0**
 TOE ANGLE / ° **1.0**
 RIDE HEIGHT / MM **4.8**
 DOWNSTOP / MM **5.6**
 UPSTOP / MM **-**
 ANTI-ROLL BAR Ø / MM **1.1**
 ARB STIFFENER 1/4 1/2 3/4 1
 LOWER ARM EXTENSION / MM **0**
 STEER. ARM AM14LS
 2ND SPRING SPR-P2 P1
 WHEEL SPACER / MM **0**
 DRIVE SPOOL DIFF
 DRIVE POSITION DOWN UP +1
 DIFF OIL DIFF SHIMS

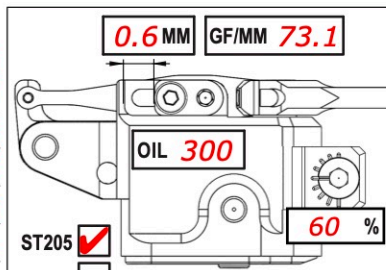

SHOCKS SETUP
 DAMPER **D4**
 ROTOR 2 HOLES
 SPRING **STD** S
 SRS/RHS ARR. I II
 PSS SETUP 30% 25% 15%
 DAMPING LINEAR P1 P2
 DAMPER SPACER / MM **0**
 C45 YES NO

REAR

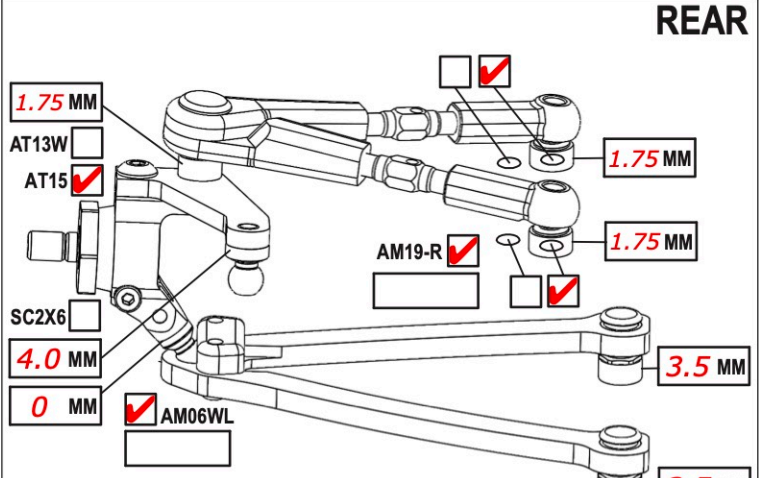

CAMBER ANGLE / ° **2.0**
 CASTER ANGLE / ° **3.0**
 TOE ANGLE / ° **2.75**
 RIDE HEIGHT / MM **5.0**
 DOWNSTOP / MM **4.6**
 UPSTOP / MM **-**
 ANTI-ROLL BAR Ø / MM **1.1**
 ARB STIFFENER 1/4 1/2 3/4 1
 LOWER ARM EXTENSION / MM **0**
 STEER. ARM AM23-1
 2ND SPRING SPR-P2 P1
 WHEEL SPACER / MM **0**
 DRIVE DIFF
 DRIVE POSITION DOWN UP +1
 DIFF OIL **8.500** DIFF SHIMS **SH5x7x0.4**

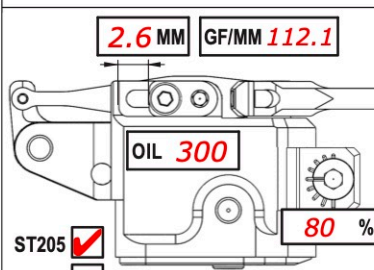

SHOCKS SETUP
 DAMPER **D4**
 ROTOR 2 HOLES
 SPRING **STD** S
 SRS/RHS ARR. I II
 PSS SETUP 30% 25% 15%
 DAMPING LINEAR P1 P2
 DAMPER SPACER / MM **0**
 C45 YES NO

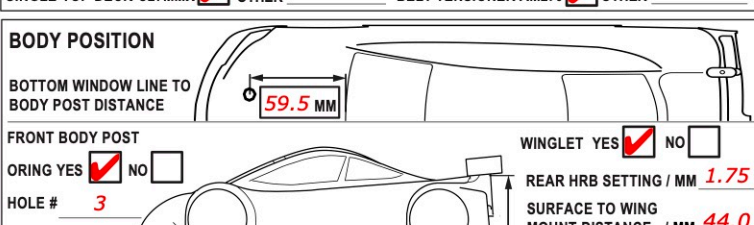
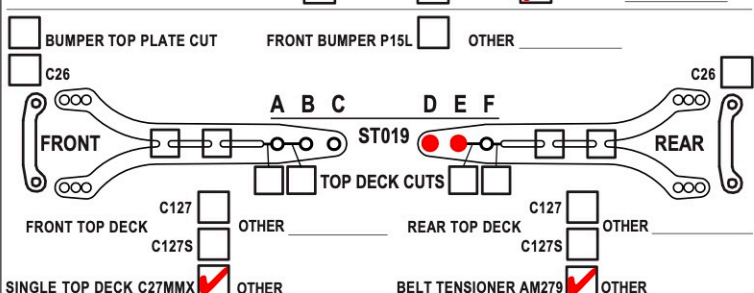
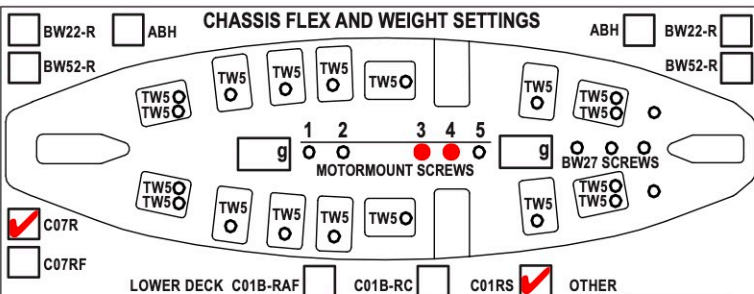

TIRES **Matrix**
 INSERTS
 SIDE WALLS GLUE Ø / MM F R
 ADDITIVE **MR33 V5** TIME MIN. F **20** R **20**
 TOTAL WEIGHT **1320** WEIGHT DISTRIBUTION % F R
 NOTES:

MOTOR LATERAL SHIFT / MM **1.0** SERVO **MKS HBL 575 SL**
 MOTOR **HW G4R 17.5T** SERVOHORN / HEIGHT **17**
 SPUR **90** PINION **45** RATIO **3.80** ACKERMANN POSITION **Backwards**
 BODY **Wolverine 0.4** STEER TRAVEL IN **24** OUT
 WING **Wolverine 0.4** BATTERY **TeamEAM 6400**
 ESC **HW ETS** RECEIVER **Sanwa RX-492i**
 ESC SETTING RADIO **Sanwa M17S**
 BEST LAPTIME QUALIF./FINAL POSITION /

COMMENTS:
Option Parts: AM279, A800-C07R, OR14V, MXLR Flex Bumper, MXLR Front & Rear Body Support, BoomRC Body Stiffner

NAME **Lukas Ellerbrock**
 RACE **TOS Apeldoorn - Carbon Car**
 TRACK **Apeldoorn**
 COUNTRY **Netherlands** CLASS **17.5T**

DATE **26.04.2026** TEMP. °C AIR / TRACK **16 /**
 TRACK SURFACE ASPHALT CARPET
 TRACK LAYOUT TECHNICAL MIXED FAST
 TRACTION LOW MEDIUM HIGH

FRONT

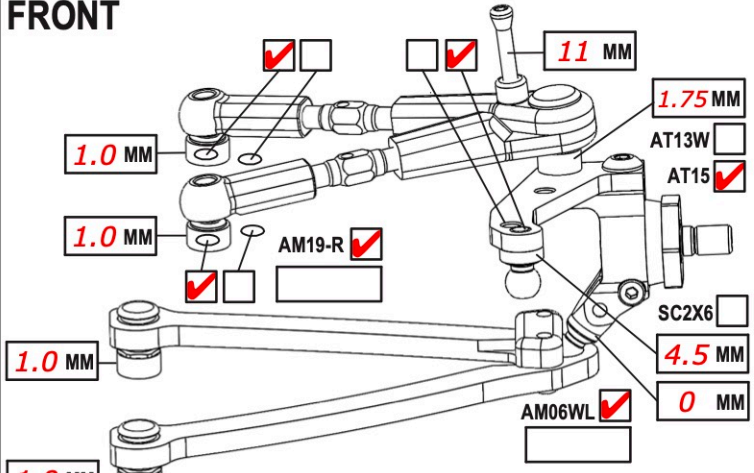

CAMBER ANGLE / ° **2.0**
 CASTER ANGLE / ° **5.0**
 TOE ANGLE / ° **1.0**
 RIDE HEIGHT / MM **4.8**
 DOWNSTOP / MM **5.6**
 UPSTOP / MM **33.0**
 ANTI-ROLL BAR Ø / MM **1.0**
 ARB STIFFENER 1/4 1/2 3/4 1
 LOWER ARM EXTENSION / MM **0**
 STEER. ARM AM14LS
 2ND SPRING SPR-P2 P1
 WHEEL SPACER / MM **0**
 DRIVE SPOOL DIFF
 DRIVE POSITION DOWN UP +1
 DIFF OIL DIFF SHIMS

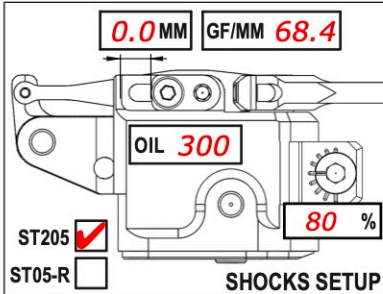

SHOCKS SETUP
 DAMPER **D4**
 ROTOR 2 HOLES
 SPRING **STD** S
 SRS/RHS ARR. **I** II
 PSS SETUP 30% 25% 15%
 DAMPING LINEAR P1 P2
 DAMPER SPACER / MM
 C45 **YES** NO

REAR

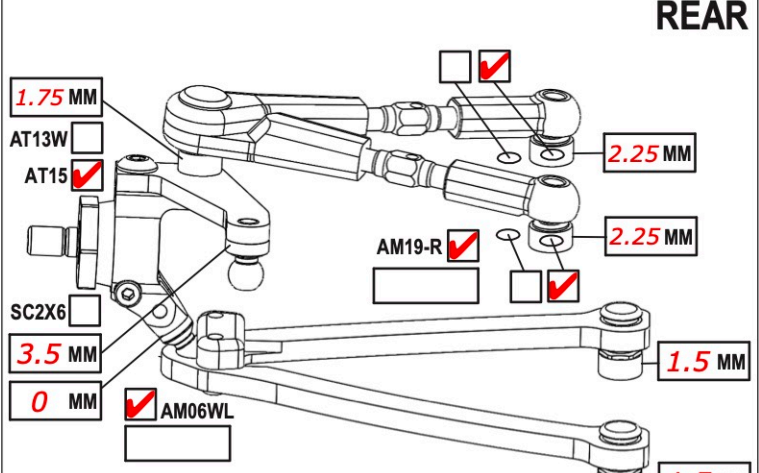

CAMBER ANGLE / ° **2.0**
 CASTER ANGLE / ° **2.0**
 TOE ANGLE / ° **2.0**
 RIDE HEIGHT / MM **5.0**
 DOWNSTOP / MM **4.6**
 UPSTOP / MM **31.0**
 ANTI-ROLL BAR Ø / MM **1.1**
 ARB STIFFENER 1/4 1/2 3/4 1
 LOWER ARM EXTENSION / MM **0**
 STEER. ARM AM23-1
 2ND SPRING SPR-P2 P1
 WHEEL SPACER / MM
 DRIVE DIFF
 DRIVE POSITION DOWN UP +1
 DIFF OIL **8.500** DIFF SHIMS **SH5x7x0.4**

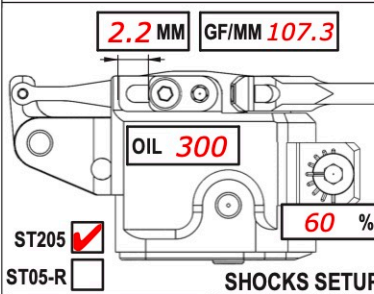

SHOCKS SETUP
 DAMPER **D4**
 ROTOR 2 HOLES
 SPRING **STD** S
 SRS/RHS ARR. **I** II
 PSS SETUP 30% 25% 15%
 DAMPING LINEAR P1 P2
 DAMPER SPACER / MM
 C45 **YES** NO

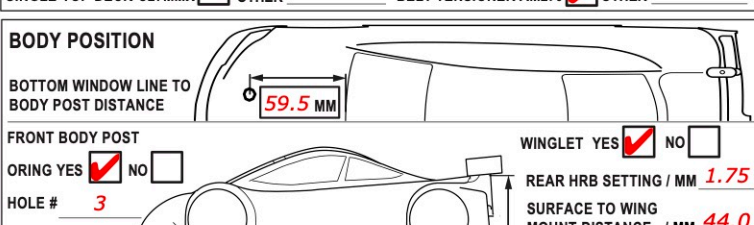
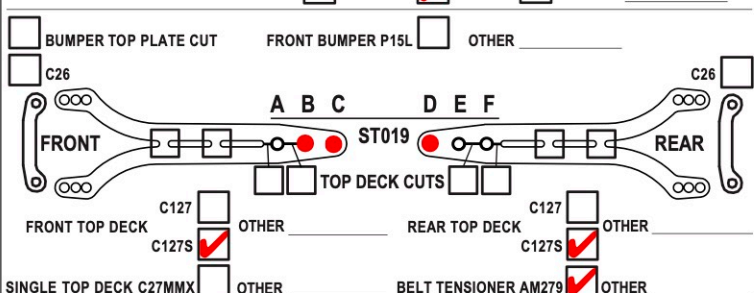
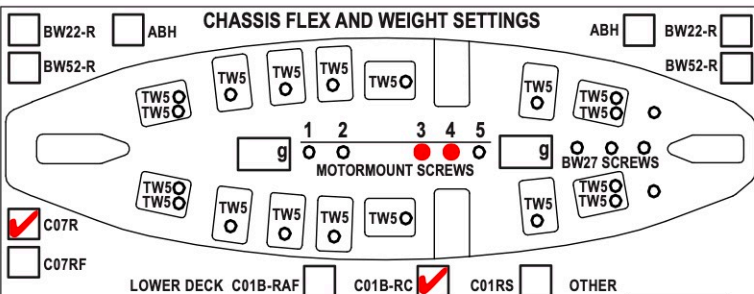

TIRES **Matrix**
 INSERTS
 SIDE WALLS GLUE Ø / MM F R
 ADDITIVE **MR33 V5** TIME MIN. F **20** R **20**
 TOTAL WEIGHT **1320** WEIGHT DISTRIBUTION % F R
 NOTES:

MOTOR LATERAL SHIFT / MM **1.0** SERVO **MKS HBL 575 SL**
 MOTOR **HW G4R 17.5T** SERVOHORN / HEIGHT **17**
 SPUR **90** PINION **45** RATIO **3.80** ACKERMANN POSITION **Backwards**
 BODY **Wolverine 0.4** STEER TRAVEL IN **24** OUT
 WING **Wolverine 0.4** BATTERY **TeamEAM 8400**
 ESC **HW ETS** RECEIVER **Sanwa RX-492i**
 ESC SETTING RADIO **Sanwa M17S**
 BEST LAPTIME QUALIF./FINAL POSITION /

COMMENTS:
Option Parts: AM279, A800-C07R, OR14V, MXLR Flex Bumper, MXLR Front & Rear Body Support, BoomRC Body Stiffner