

NAME **Simon Lauter**
 RACE **TOS**
 TRACK **ETS Wiener Neustadt**
 COUNTRY **Austria** CLASS **Mod**

DATE **19.-22.03.** TEMP. °C AIR / TRACK **18 /**
 TRACK SURFACE ASPHALT CARPET
 TRACK LAYOUT TECHNICAL MIXED FAST
 TRACTION LOW MEDIUM HIGH

FRONT

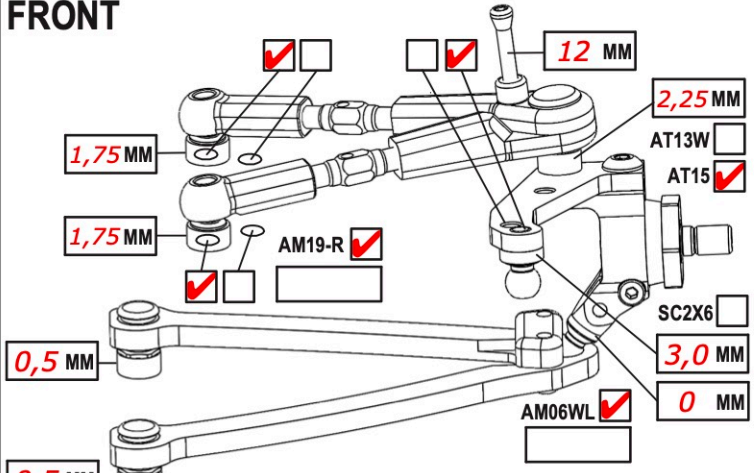

CAMBER ANGLE / ° **1.5**
 CASTER ANGLE / ° **4.0**
 TOE ANGLE / ° **1.0**
 RIDE HEIGHT / MM **5.0**
 DOWNSTOP / MM **6.4**
 UPSTOP / MM **24**
 ANTI-ROLL BAR Ø / MM **1.0**
 ARB STIFFENER 1/4 1/2 3/4 1
 LOWER ARM EXTENSION / MM **0**
 STEER. ARM AM14LS
 2ND SPRING SPR-P2 P1
 WHEEL SPACER / MM **0**
 DRIVE SPOOL DIFF
 DRIVE POSITION DOWN UP +1
 DIFF OIL DIFF SHIMS

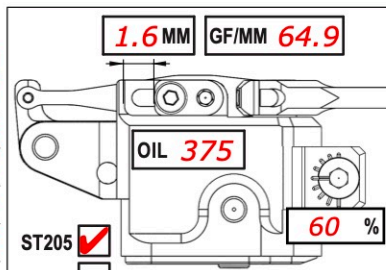

SHOCKS SETUP
 ST205 ST05-R
 DAMPER D4
 ROTOR 2 HOLES
 SPRING STD S
 SRS/RHS ARR. I II
 PSS SETUP 30% 25% 15%
 DAMPING LINEAR P1 P2
 DAMPER SPACER / MM **ST237**
 C45 YES NO

REAR

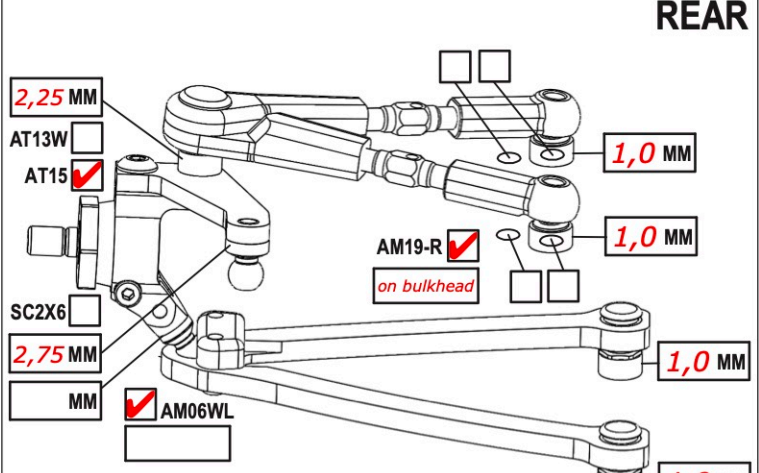

CAMBER ANGLE / ° **1.25**
 CASTER ANGLE / ° **3.0**
 TOE ANGLE / ° **3.0**
 RIDE HEIGHT / MM **5.2**
 DOWNSTOP / MM **4.6**
 UPSTOP / MM **24**
 ANTI-ROLL BAR Ø / MM **1.1**
 ARB STIFFENER 1/4 1/2 3/4 1
 LOWER ARM EXTENSION / MM **0**
 STEER. ARM AM23-1
 2ND SPRING SPR-P2 P1
 WHEEL SPACER / MM **0**
 DRIVE SPOOL DIFF
 DRIVE POSITION DOWN UP +1
 DIFF OIL **5K** DIFF SHIMS **5x7x0.4**

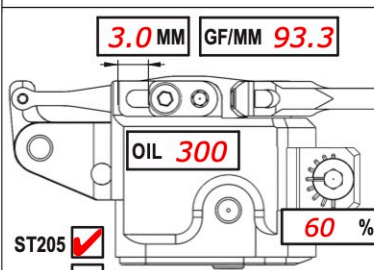

SHOCKS SETUP
 ST205 ST05-R
 DAMPER D4
 ROTOR 2 HOLES
 SPRING STD S
 SRS/RHS ARR. I II
 PSS SETUP 30% 25% 15%
 DAMPING LINEAR P1 P2
 DAMPER SPACER / MM **ST237**
 C45 YES NO

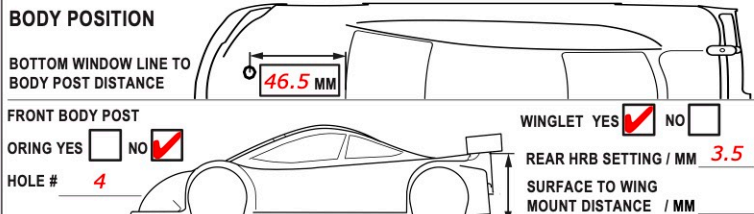
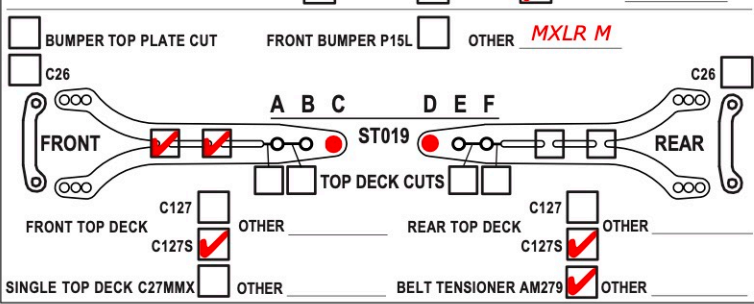
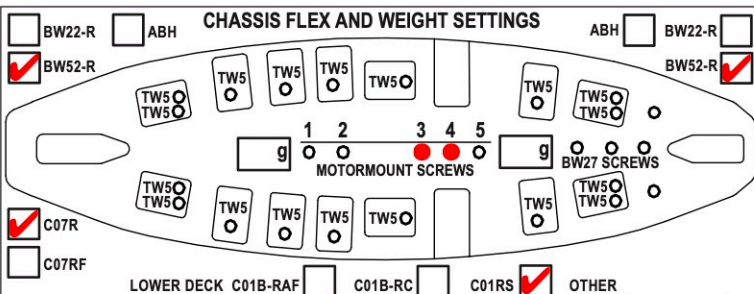

TIRES **Matrix 28**
 INSERTS
 SIDE WALLS GLUE Ø / MM F R
 ADDITIVE **MR33 V5** TIME MIN. F **20** R **20**
 TOTAL WEIGHT **1285g** WEIGHT DISTRIBUTION % F R
 NOTES:

MOTOR LATERAL SHIFT / MM **0.5** SERVO **MKS HBL575SL**
 MOTOR **HW 5T (12.3 - 30°)** SERVOHORN / HEIGHT **17mm**
 SPUR **114** PINION **30** RATIO **7.22** ACKERMANN POSITION **Rear**
 BODY **Speciale 0.4** STEER TRAVEL IN **25°** OUT
 WING **Twister 0.5** BATTERY **Nosram 4200mAh**
 ESC **Hobbywing G3** RECEIVER **RX 492**
 ESC SETTING RADIO **Sanwa M17S**
 BEST LAPTIME **15,2** QUALIF./FINAL POSITION **4 / 4**

COMMENTS:
SB3x5AL / C07R / AT15 / AT144 / BW7 / BW8
Diff 160 on SkyRC checker