

NAME **Ji-heon Yoo**  
 RACE **AC opening RACE**  
 TRACK **AC speedway**  
 COUNTRY **south korea** CLASS **Mod**

DATE **26.05.24** TEMP. °C AIR / TRACK **25 /**  
 TRACK SURFACE ASPHALT  CARPET   
 TRACK LAYOUT TECHNICAL  MIXED  FAST   
 TRACTION LOW  MEDIUM  HIGH

### FRONT

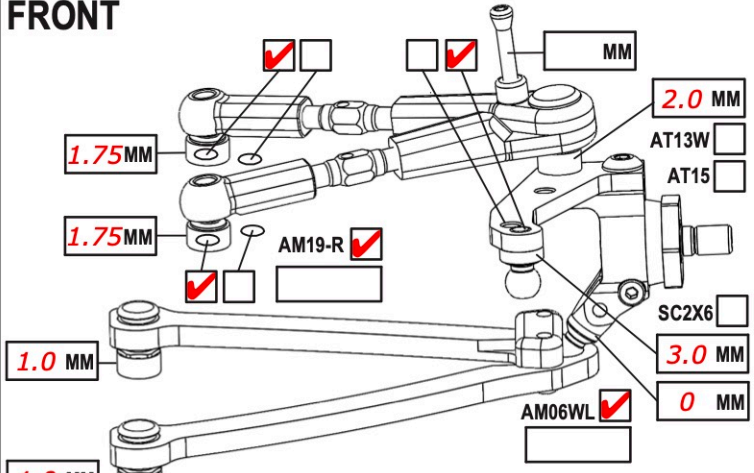

CAMBER ANGLE / ° **1.5**  
 CASTER ANGLE / ° **4.0**  
 TOE ANGLE / ° **1.2**  
 RIDE HEIGHT / MM **4.8**  
 DOWNSTOP / MM **5.8**  
 UPSTOP / MM **0**  
 ANTI-ROLL BAR Ø / MM **1.1**  
 ARB STIFFENER 1/4  1/2  3/4  1   
 LOWER ARM EXTENSION / MM **0**  
 STEER. ARM AM14LS   
 2ND SPRING SPR-P2  P1   
 WHEEL SPACER / MM **0**  
 DRIVE SPOOL  DIFF   
 DRIVE POSITION DOWN  UP  +1  
 DIFF OIL  DIFF SHIMS

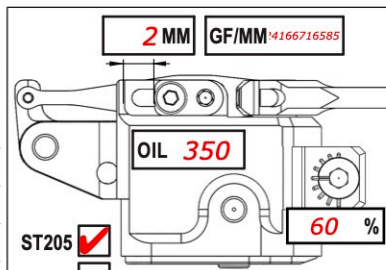

**SHOCKS SETUP**  
 DAMPER **D4**   
 ROTOR 2 HOLES   
 SPRING **STD**  S   
 SRS/RHS ARR. **I**  II   
 PSS SETUP 30%  25%  15%   
 DAMPING LINEAR  P1  P2   
 DAMPER SPACER / MM **+ST237**  
 C45 YES  NO

### REAR

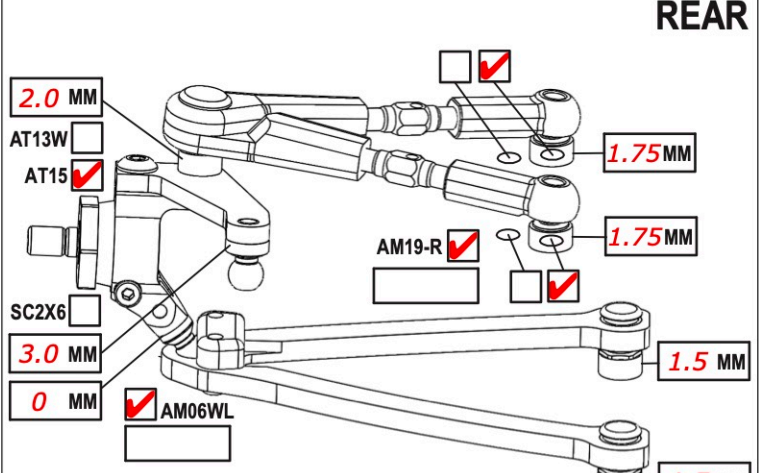

CAMBER ANGLE / ° **1.5**  
 CASTER ANGLE / ° **-2.0**  
 TOE ANGLE / ° **2.75**  
 RIDE HEIGHT / MM **5.0**  
 DOWNSTOP / MM **4.6**  
 UPSTOP / MM **0**  
 ANTI-ROLL BAR Ø / MM **1.1**  
 ARB STIFFENER 1/4  1/2  3/4  1   
 LOWER ARM EXTENSION / MM **0**  
 STEER. ARM AM23-1   
 2ND SPRING SPR-P2  P1   
 WHEEL SPACER / MM **0**  
 DRIVE DIFF   
 DRIVE POSITION DOWN  UP  +1  
 DIFF OIL **MR33 7k** DIFF SHIMS **SH5X7X0.4**

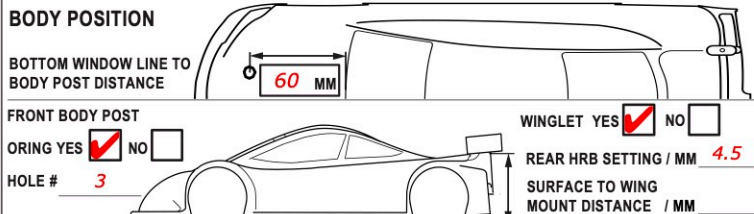
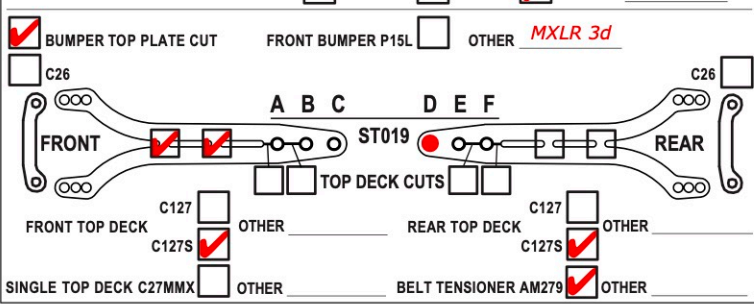
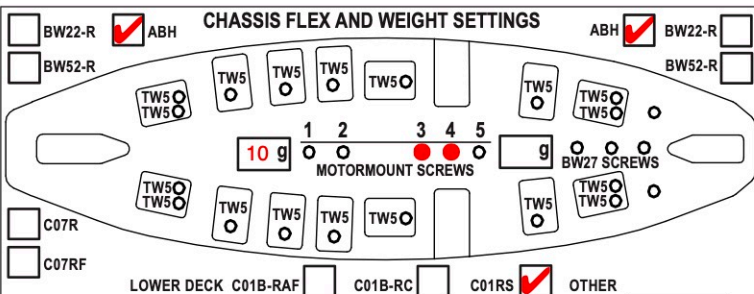
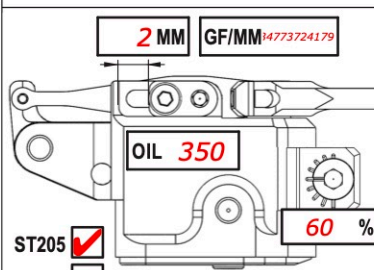

TIRES **SWEEP D32**  
 INSERTS **SWEEP D32**  
 SIDE WALLS GLUE Ø / MM F **0** R **0**  
 ADDITIVE **MG V3 Yellow** TIME MIN. F **10** R **10**  
 TOTAL WEIGHT **1302** WEIGHT DISTRIBUTION % F **51** R **49**  
 NOTES: **62deg warming**

MOTOR LATERAL SHIFT / MM **12.3** SERVO **PowerHD GTS-2**  
 MOTOR **Hobbywing 4,5T (30°)** SERVOHORN / HEIGHT **17mm MXLR**  
 SPUR **111** PINION **29** RATIO <sup>793103447</sup> ACKERMANN POSITION **backward**  
 BODY **Xtreme Speciale UL** STEER TRAVEL IN **24** OUT **16**  
 WING **Xtreme Speciale UL** BATTERY **LRP 6500**  
 ESC **HW XR10 Pro G3** RECEIVER **Sanwa 492**  
 ESC SETTING RADIO **Sanwa M17s**  
 BEST LAPTIME QUALIF./FINAL POSITION **1st / 1st**

COMMENTS:  
**BW10, BW7, BW8, AT21-Ti, BS1-Ti, ST03-Ti SB3X5AL Screws on top of the car**