

NAME **Timon Coenen**  
 RACE **TOS Round 1**  
 TRACK **Amca Apeldoorn**  
 COUNTRY **Netherlands** CLASS **17.5T**

DATE **26.04.2026** TEMP. °C AIR / TRACK /  
 TRACK SURFACE ASPHALT  CARPET   
 TRACK LAYOUT TECHNICAL  MIXED  FAST   
 TRACTION LOW  MEDIUM  HIGH

### FRONT

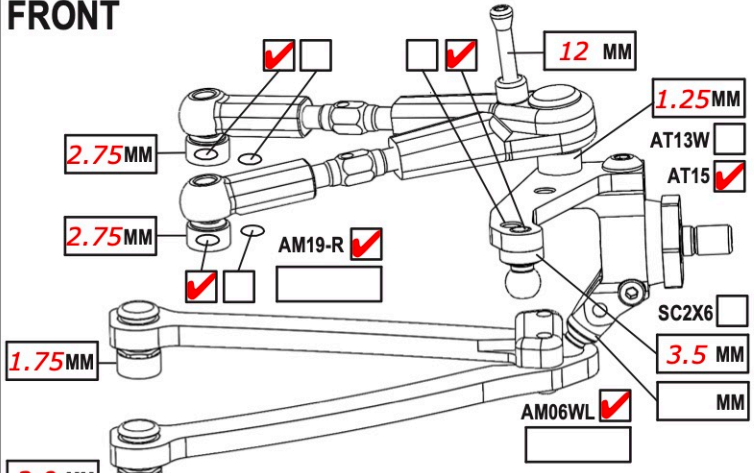

CAMBER ANGLE / ° **1.7**  
 CASTER ANGLE / ° **4.2**  
 TOE ANGLE / ° **1.0**  
 RIDE HEIGHT / MM **4.8**  
 DOWNSTOP / MM **5.8**  
 UPSTOP / MM  
 ANTI-ROLL BAR Ø / MM **1.1**  
 ARB STIFFENER 1/4  1/2  3/4  1   
 LOWER ARM EXTENSION / MM **0**  
 STEER. ARM AM14LS   
 2ND SPRING SPR-P2  P1   
 WHEEL SPACER / MM  
 DRIVE SPOOL  DIFF   
 DRIVE POSITION DOWN  UP  +1  
 DIFF OIL DIFF SHIMS

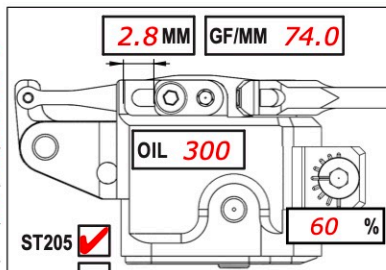

ST205  ST05-R  SHOCKS SETUP  
 DAMPER D4   
 ROTOR 2 HOLES   
 SPRING STD  S   
 SRS/RHS ARR. I  II   
 PSS SETUP 30%  25%  15%   
 DAMPING LINEAR  P1  P2   
 DAMPER SPACER / MM **1.0**  
 C45 YES  NO

### REAR

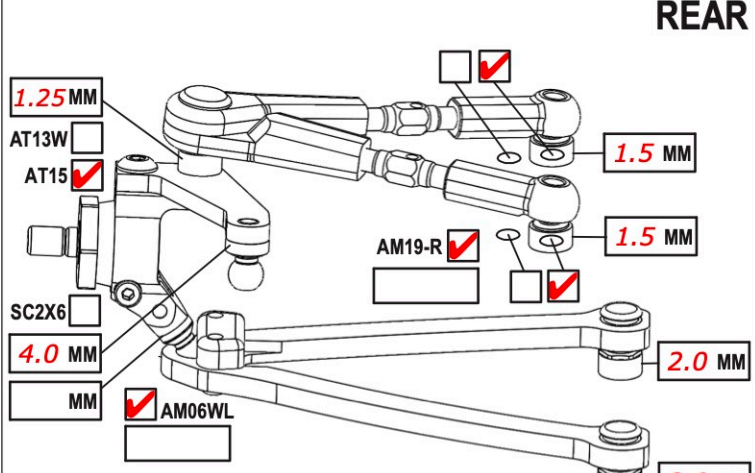

CAMBER ANGLE / ° **1.7**  
 CASTER ANGLE / ° **3.0 (old, 3.5)**  
 TOE ANGLE / ° **2.25 (old, 1.75)**  
 RIDE HEIGHT / MM **5.0 (old, 5.2)**  
 DOWNSTOP / MM **4.4 (old, 4.0)**  
 UPSTOP / MM  
 ANTI-ROLL BAR Ø / MM **1.2**  
 ARB STIFFENER 1/4  1/2  3/4  1   
 LOWER ARM EXTENSION / MM **0**  
 STEER. ARM AM23-1  **AM23-R**  
 2ND SPRING SPR-P2  P1   
 WHEEL SPACER / MM **0.5 on old**  
 DRIVE DIFF   
 DRIVE POSITION DOWN  UP  +1  
 DIFF OIL **7k** DIFF SHIMS **SH5X7X0.4**

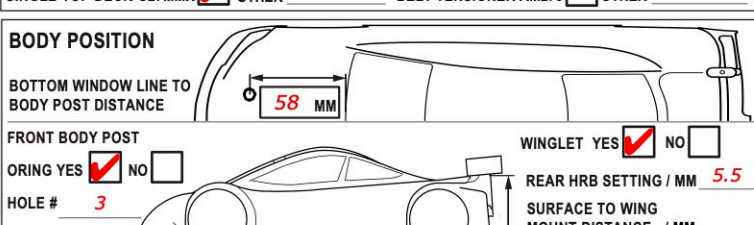
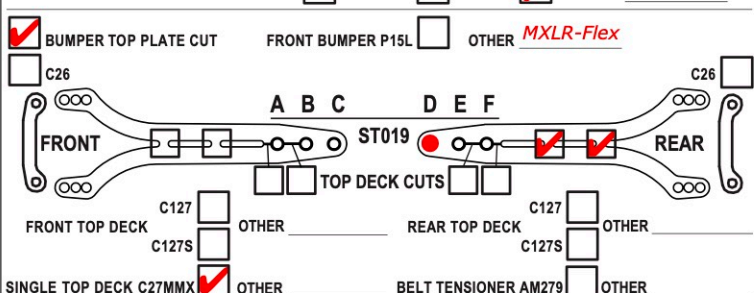
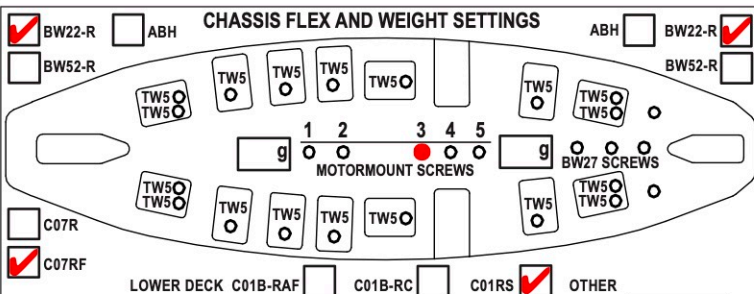
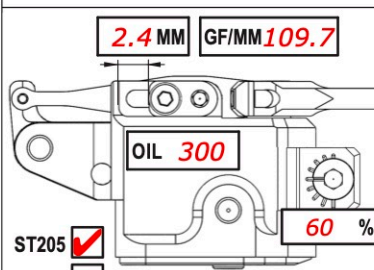

TIRES **Matrix Z36**  
 INSERTS  
 SIDE WALLS GLUE Ø / MM F R  
 ADDITIVE **MR33 V3** TIME MIN. F **20** R **20**  
 TOTAL WEIGHT **1325** WEIGHT DISTRIBUTION % F **50** R **50**

NOTES:  
 MOTOR LATERAL SHIFT / MM **1.75** SERVO **PowerHD GTS2**  
 MOTOR **ETS HW G4R 17.5t** SERVOHORN / HEIGHT **18**  
 SPUR **90** PINION **45** RATIO **3.80** ACKERMANN POSITION **back**  
 BODY **wolverine max 0.4** STEER TRAVEL IN **24** OUT  
 WING **twister 0.7** BATTERY **EAM 6400**  
 ESC **ETS HW XR10 Stock Spec** RECEIVER **Sanwa**  
 ESC SETTING **21k** RADIO **Sanwa**  
 BEST LAPTIME QUALIF./FINAL POSITION /

COMMENTS: